

Classification of KJA Net Conditions Using ROV and Computer Vision

Nurhaliza Amalia Lestari*¹, Indra Jaya², Ayi Rahmat³, Totok Hestirianoto⁴

^{1,2,3,4}Department of Marine Technology, Graduate School of IPB University, Bogor, Indonesia

^{1,2}Center for Coastal and Marine Resources Studies, IPB University, Bogor, Indonesia

e-mail: *na.lestari@apps.ipb.ac.id, indrajaya@apps.ipb.ac.id, ayi_rachmat@apps.ipb.ac.id, hestirianoto@gmail.com

Abstrak

Pengembangan dan integrasi Remotely Operated Vehicle (ROV) dengan computer vision telah dilakukan dan menunjukkan kinerja yang sangat baik. Seluruh fungsi fitur ROV berjalan dengan lancar dan tanpa kendala serta mampu memantau kondisi jaring di keramba jaring apung (KJA) dan menghasilkan video bawah air. Data yang dikumpulkan dari ROV diolah menggunakan model YOLOv8 dan menunjukkan hasil yang sangat positif dalam mengklasifikasikan kondisi jaring KJA. Model ini mencapai tingkat akurasi 1 atau 100% dalam membedakan jaring bersih dan kotor. Berdasarkan hasil tersebut dapat disimpulkan bahwa model YOLOv8 memiliki performa yang sangat baik dalam mengenali objek jaring dengan tingkat akurasi yang tinggi. Hasil ini memberikan keyakinan bahwa model ini dapat dipercaya dalam memantau kondisi jaringan KJA.

Kata kunci : *Computer Vision, Jaring, KJA, ROV, YOLOv8*

Abstract

The development and integration of a Remotely operated vehicle (ROV) with computer vision has been carried out and shows excellent performance. All ROV features functions run smoothly and without problems and can monitor the condition of nets in floating net cages (KJA) and produce underwater videos. Data collected from ROV are processed, utilizing the YOLOv8 model, and showed very positive results in classifying the condition of KJA nets. The model achieves an accuracy level of 1 or 100%, differentiating between clean and dirty nets. Based on these results, it can be concluded that the YOLOv8 model has excellent performance in recognizing mesh objects with a high level of accuracy. These results provide confidence that this model can be trusted in monitoring the condition of KJA nets.

Keywords: *Computer Vision, Net, KJA, ROV, YOLOv8*

1. INTRODUCTION

Aquaculture is very important in meeting animal protein food needs in Indonesia and the world. As the global population grows, seafood consumption also increases. According to data from the Ministry of Maritime Affairs and Fisheries, in 2020, aquaculture production reached 19.8 million tonnes, with a contribution of 49.02% to total fisheries production in Indonesia [1]. [2] also stated that aquaculture is an important global industry that provides

important food for the world's growing population.

Cultivating seawater fish using the floating net cage (KJA) method is considered the right choice because it has several advantages compared to other cultivation methods, namely ease of management and efficiency [3], less space required [4], does not require special water management [5], and is easy to harvest [6].

Even though it has many advantages, cultivating seawater fish using the KJA method also faces several challenges and problems, one of which is dirt and biota (biofouling) that stick to the net, causing water circulation to be blocked [7]. The buildup of dirt and biofouling in the nets can affect the water quality in the cage, which can affect the health and growth of fish. If dirt and biofouling are not regularly removed from nets, it can cause waste to build up at the bottom of the marine cage and create poor environmental conditions for fish [8]. Therefore, it is necessary to carry out routine monitoring and maintenance on KJA.

Monitoring the condition of nets in marine cages in Indonesia is still rarely carried out due to human limitations and threats from unpredictable water conditions. Research using a Remotely Operated Vehicle (ROV) is one way to overcome human limitations in waters without having to dive [9]. ROV is a type of underwater robot with applications aimed at carrying out underwater activities. In operation [10]. ROV technology integrated with computer vision (CV) algorithms is expected to be a solution in efforts to monitor nets in KJA.

Computer vision (CV) is an automatic process that integrates a large number of processes for visual perception, such as image acquisition, image processing, recognition, and decision-making [11]. Thus, this research aims to create an ROV that is effective, efficient, and easy to use for monitoring KJA and analyzing KJA condition data in the form of images with classification using computer vision algorithms.

2. METHODS

The research work procedure consists of several stages, namely instrument design, laboratory scale testing, instrument creation, instrument testing, field data collection, monitoring model creation, and model evaluation.

2.1 Tool Design

The ROV electronic system is divided into several units (Figure 1), namely the microprocessor as the calculation centre and decision maker in carrying out movements, as well as the microcontroller to read sensors and implement decisions taken by the microprocessor.

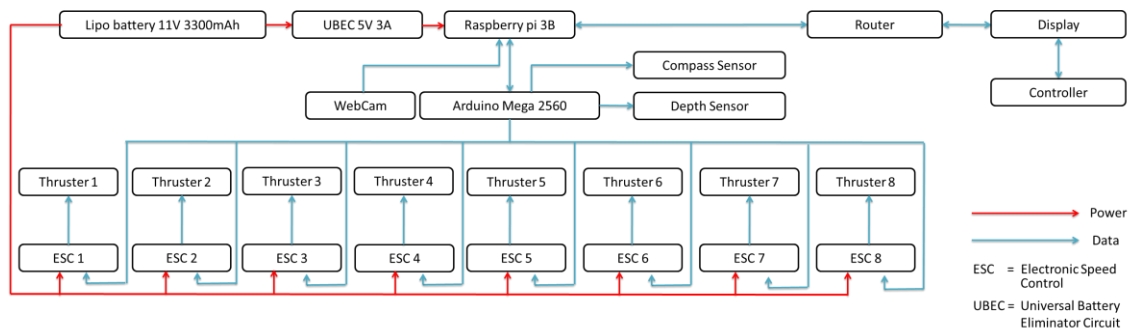

Figure 1 Functional relationships of electronic systems

The power supply used to power all electronic components is a 3-cell LiPo 3300 mAh battery. Battery life is calculated using the following formula:

$$\text{Battery Life} = \frac{\text{Battery Capacity (mAh)}}{\text{Load Current (mA)}} \quad (1)$$

2.2 Laboratory Test

2. 2.1 Straight forward movement

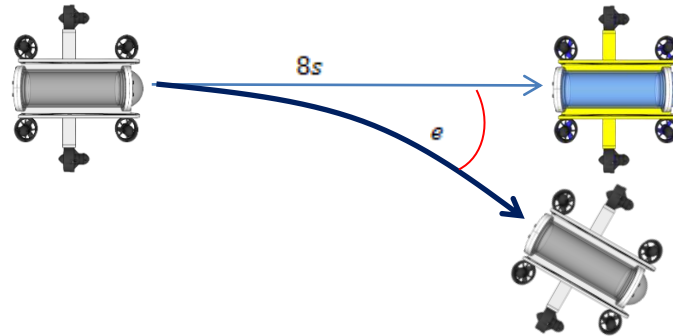

Figure 2 Illustration of the forward movement test

Forward motion analysis involves comparing the direction at the beginning and end of the movement. In this forward motion example, the probe moves forward for 8 seconds.

$$e = d1 - d0 \quad (2)$$

2. 2.2 Downward movement

Analysis of the descent movement looks at the differences in depth and the time required when the vehicle completes its descent movement for 8 seconds.

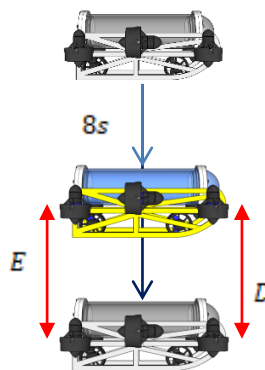

Figure 3 Illustration of the descent movement test

$$E = p1 - p0 \quad (3)$$

$$D = t1 - t0 \quad (4)$$

2. 2.3 Turning movement

The turning movement is analyzed in the form of the difference in direction and the time required to reach a complete stop position after reaching a direction of 90°.

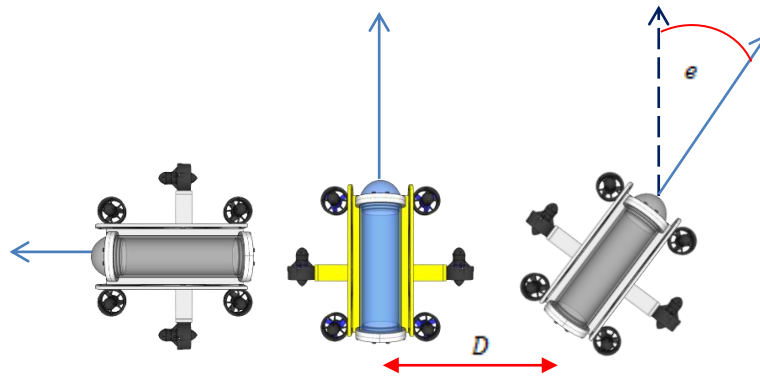

Figure 4 Illustration of the turning movement test

$$e = d1 - d0 \quad (5)$$

$$D = t1 - t0 \quad (6)$$

Information:

e: Difference between hypothetical and actual directions ($^{\circ}$)

d0: ROV direction at initial position ($^{\circ}$)

d1: ROV direction at final position ($^{\circ}$)

E: Difference between hypothetical and actual depth (cm)

p0: Initial depth of ROV (cm)

p1: Final depth of ROV (cm)

D: Time delay for the ROV to reach rest (s)

t0: The time the ROV starts to move (s)

t1: The time the ROV stops moving (s)

2.3 Field Data Collection

Field data collection was carried out by recording the condition of the KJA net and producing video using a camera installed on the ROV. The recording results are then extracted into images or pictures to be used as a dataset.

2.4 Data Analysis

2.4.1 Color correction

According to [12], the use of computer vision requires truly clear images; therefore, the dataset used for training will go through a colour correction process to improve image quality.

2.4.2 Labeling

The purpose of image labelling is to match the image with the net in KJA so that it can be identified during the training process. The dataset is divided into 70% training data, 20% validation data, and 10% testing data.

2.4.3 Training

The training dataset was carried out using a deep learning algorithm called YOLOv8. The YOLO (You Only Look Once) algorithm has the task of classifying the detected objects. YOLOv8 is the latest version of YOLO and is designed to be fast, accurate, and easy to use, making it an excellent choice for a variety of object detection and image segmentation tasks [13].

2.5 Model Evaluation

Evaluation of the model in this study uses a confusion matrix. A confusion matrix is a matrix that represents classification assumptions and actual classification [14] and is used as a

reference to find out whether the algorithm works well or not. The confusion matrix used in this research can be seen in Table 1.

Table 1 Confusion Matrix [15]

	Actual True	Actual False
Predicted True	<i>true positive (TP)</i>	<i>false positive (FP)</i>
Predicted False	<i>false negative (FN)</i>	<i>true negative (TN)</i>

In the context of the confusion matrix, the following equation [16] can be used to calculate accuracy, precision, and recall:

$$Accuracy = \frac{TP + TN}{TP + FP + TN + FN} \quad (7)$$

$$Precision = \frac{TP}{TP + FP} \quad (8)$$

$$Recall = \frac{TP}{TP + FN} \quad (9)$$

3. RESULTS AND DISCUSSION

3.1 ROV Design Results

The Remotely Operated Vehicle (ROV) instrument has been successfully created, as seen in Figure 5. Initially, this vehicle was designed to participate in AUV-type competitions but then transformed into an ROV by creating a new control program and video acquisition system. To better understand the general specifications of the ROV used in this research, you can see Table 2.

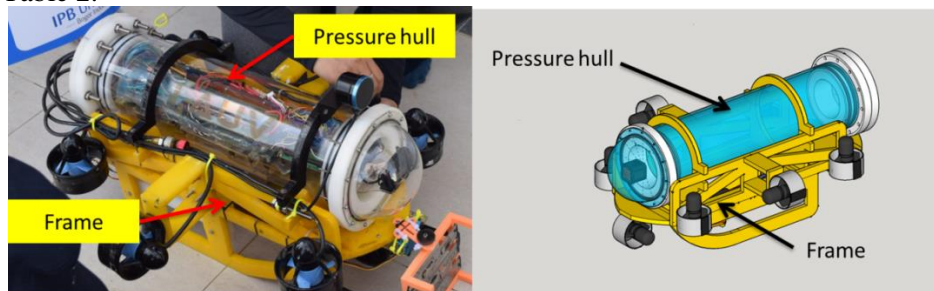

Figure 5 ROV design results

Table 2 ROV Specifications

Specification	
Weight	13 kg
Dimensions	61x65x34 cm
Thruster Motor	8 (4 horizontal + 4 vertical)
Battery	3300 mAh / 11.1V / 3 cell
Battery life	2.94 h
Camera	Webcam Logitech B525

The duration of use or ignition of the vehicle can be based on calculations of the electronic components contained in the vehicle. The total current produced by the electronic

components is 1120 mA with a total power of 4.4 W. Detailed electrical specifications for the components can be seen in Table 3.

Table 3 Electrical specifications of components

Modul	Quantity	Voltage (V)	Ampere (mA)	Power (W)
Raspberry Pi 3	1	5	400	2
Arduino Mega	1	5	200	1
LCD 16x2	1	5	120	0.6
Blue Robotic ESC*	8	10	400	0.5
Total			1120	4,4

*Assuming all eight ESCs are used simultaneously and continuously with the PWM 1550

With the total current used by the vehicle known, the power load supplied by the battery can be calculated so that the duration of the vehicle's running time can be determined as follows.

$$\text{Battery life} = \text{Battery Capacity} / \text{Load Current} = 3300 \text{ mAh} / 1120 \text{ mA} = 2.94 \text{ h}$$

3.2 Laboratory Test Results

Laboratory scale tests were carried out in July 2023 at the Aquatic Sport Center (ASC) IPB by carrying out movements such as forward movements, downward movements, and turning movements. The graph of the analysis results can be seen in Figure 6 to Figure 8 and is followed by a table of analysis results in Table 4 to Table 7.

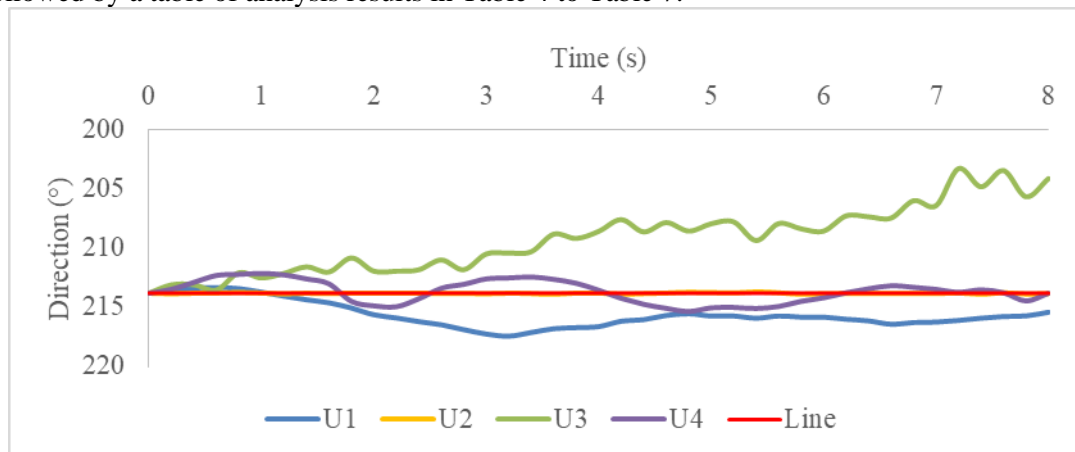

Figure 6 Graph of straight movement patterns

Table 4 Results of delay and error analysis of straight movement

Direction (°)	Test			
	U1	U2	U3	U4
Initial direction	213.8	213.8	213.8	213.8
final direction	215.4	213.9	204.1	213.8
error	1.6	0.11	9.7	0

In the results of the straight movement in the pool, it can be seen that the lowest error was in the fourth trial with an error of 0°, and the highest error was in the third trial with an error of 9.7°. If you look at the movement pattern of the vehicle, this happens because, in each experiment, different coefficients are used for the right and left forward motors.

Table 5 Forward motor speed coefficient

Test	PWM		
	Base	Right motor	Left motor

1	1550	1560	1555
2	1550	1560	1554
3	1550	1559	1555
4	1550	1561	1554

In this straight motion test, several different coefficients were applied to each trial to obtain motion with the lowest error, which was obtained for the right motor coefficient of 11 and the left motor coefficient of 4 with details of PWM and speed in Table 5.

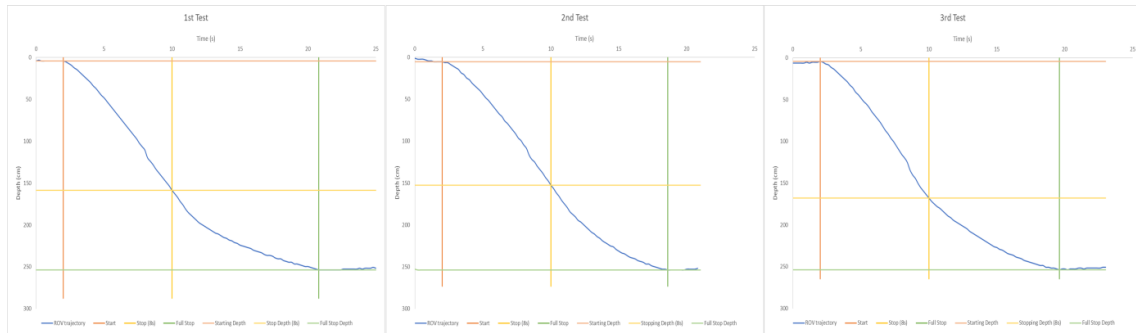

Figure 7 Graph of downward movement

Table 6 Results of analysis of delay and error in descending motion

	Time (s)			Depth (cm)			Average delay/error	
	U1	U2	U3	U1	U2	U3	Time (s)	Depth (cm)
Initial Condition	2	2.2	2	4.1	5.1	4.1	9.7	94.1
Stop command (8s)	10	10.2	10	158.5	152.4	167.7		
Full stop	20.8	18.8	19.6	253.6	253.6	253.6		
delay/error	10.8	8.6	9.6	95.1	101.2	85.9		

The descent test had an average delay of 9.7 seconds with a depth error of 94.1 cm. This means that from the time the command was given to stop moving after 8 seconds, the vehicle continued to move down during the delay time, and the error was equal. This is because the ratio of the vehicle's buoyant force and gravitational force is close to the same.

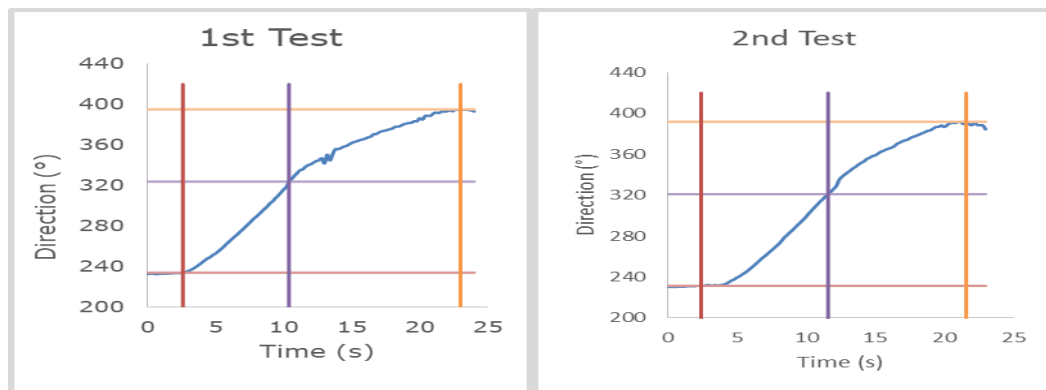

Figure 8 Turning movement graph

Table 7 Results of analysis of turning delays and errors

	Waktu (s)		Arah (°)		Rata-rata <i>delay/error</i>	
	U1	U2	U1	U2	Waktu (s)	Arah (°)
Initial Condition	2.6	3.8	223.4	231	11.3	71
Stop command (90°)	10.4	11.6	313.4	321		
Full stop	23	21.6	395	391,7		
delay/error	12.6	10	71.3	70		

The turning movement test results produced an average delay and error of 11.3 seconds and 71°. This result was obtained by calculating the length of time required from the time the stop command was given until the vehicle stopped completely or was delayed, where the difference in direction when the command was given and the final direction of the vehicle was an error in movement.

3.3 Results of Field Data Collection

Based on the recording results, a net video was obtained with a total duration of approximately 6 minutes with a resolution of 640x480 pixels and a framerate of 20 fps. The extraction process produced 7,156 images. According to [17], the more datasets there are, the better the model will recognize objects in images. The selected data must represent various kinds of background and feature objects so that the learning results of the YOLOv8 algorithm are better.

3.4 Data Analysis Results

The dataset in the form of images will go through a white balance process first to improve image quality. The application of white balance aims to avoid unwanted colour distribution and minimize distortion effects [18].

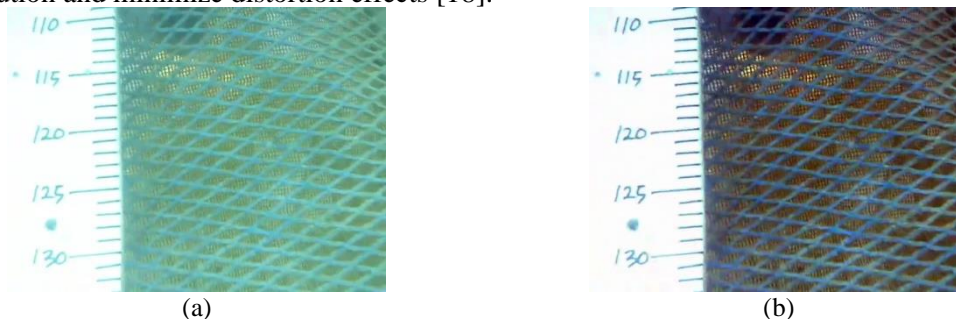

Figure 9 Underwater image from monitoring KJA nets; (a) before colour correction; (b) after colour correction

Colour correction using the white balance method succeeded in removing non-neutral colours in the dataset (figure 9). The number of images that became a dataset after going through the selection and colour correction stages was 741 images. The dataset is divided into a clean net class of 348 images and a dirty net class of 393 images, which are then labelled according to their respective classes using Roboflow software.

The dataset training stage was carried out using the YOLO v8 model and was carried out with 50 epochs. Epoch is the number of iterations, or training cycles carried out by the algorithm [19]. It is important to note that too many epochs can also lead to overfitting [20]. Overfitting occurs when a model learns patterns in the training dataset excessively or in too much detail so that it cannot generalize well to new data that has never been seen before.

The training dataset produces a training loss graph (figure 10). Training loss is an error measure calculated based on the difference between the model's predicted values and the actual

labels at each training iteration [21]. The lower the training loss value or closer to zero, the better the model's ability to recognize the object to be identified [22].

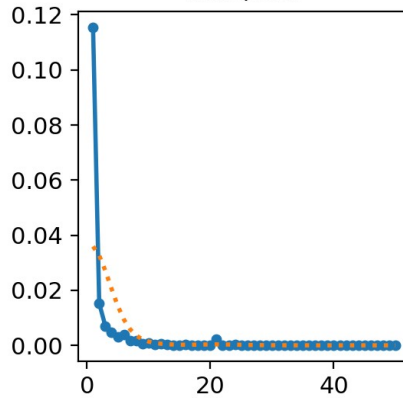

Figure 10 YOLOv8 training loss graph

In this research, the training loss results using the YOLOv8 model were 0.00004. These results indicate that the model that has been trained has a good ability to understand the characteristics of the condition of the KJA net and can recognize these objects with high accuracy.

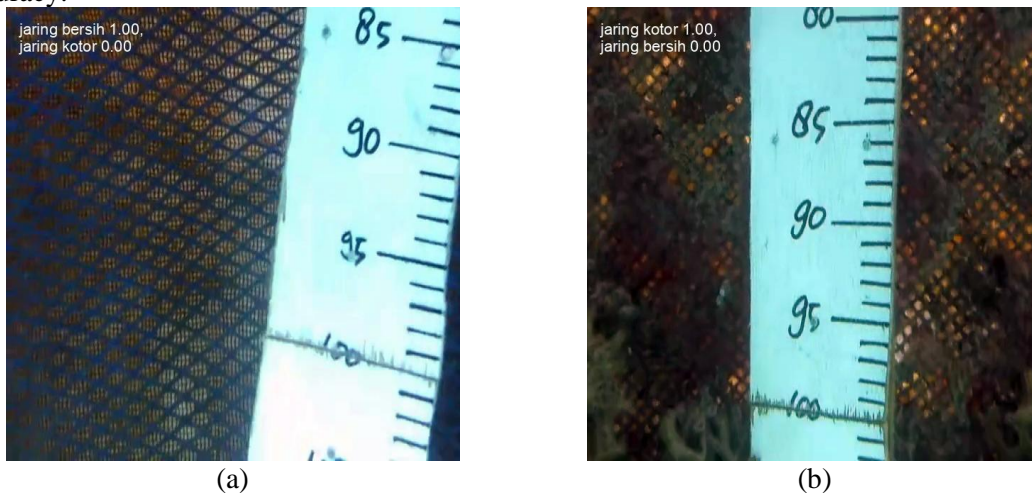

Figure 11 Results of classification of KJA net conditions; (a) “jaring bersih” classification results; (b) “jaring kotor” classification results

Classification aims to identify classes of objects according to the labels that have been given. In the classification results, it can be seen that there are label names and numbers. This figure shows the confidence score value, which ranges from 0 to 1 [23]. The confidence score is a value that indicates the extent to which the model has confidence in detecting objects and measures the accuracy of detected objects [23]. The higher the confidence score, the greater the model's confidence in the detected object.

3.5 Model Evaluation

Analyzing the confusion matrix gives deeper insight into the performance of the detection model. The results of the confusion matrix on the classification of KJA net conditions using the YOLOv8 model can be seen in Figure 12.

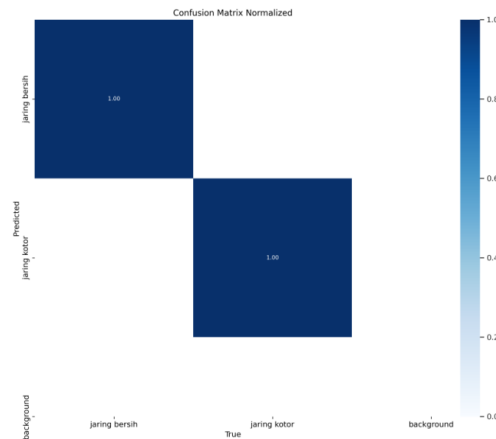

Figure 12 Confusion matrix results

Through confusion matrix numbers, you can calculate evaluation metrics such as accuracy, precision, and recall. The accuracy, precision, and recall equations of the YOLOv8 confusion matrix can be calculated as follows:

$$Accuracy = \frac{1 + 1}{1 + 0 + 1 + 0} = 1$$

$$Precision = \frac{1}{1 + 0} = 1$$

$$Recall = \frac{1}{1 + 0} = 1$$

In this research, calculating the confusion matrix equation produces accuracy, precision, and recall values of 1. According to [24], an accuracy value of 1 indicates that the model achieves perfect classification, while a value of 0 indicates very poor classification. A precision value of 1 indicates that all objects predicted as positive are correct, while a value of 0 indicates that no objects are correctly predicted as positive. A recall value of 1 indicates that the model successfully detected all positive objects, while a value of 0 indicates that no objects were successfully detected as positive.

Based on the results of the model evaluation, the confidence score, accuracy, precision, and recall values were 1 or achieved a perfect classification value. This can happen because the data and classes used for training are less varied so that the model can easily classify images into predetermined classes.

4. CONCLUSIONS

The development and integration of a Remotely operated vehicle (ROV) with computer vision shows excellent performance. The ROV has a buoyancy force of 128.38 Kg m/s² and a running duration of 2.94 hours. The ROV motion test results show the lowest error value, namely 0° for forward motion, an average delay of 9.7 seconds with a depth error of 94.1 cm for descending motion, an average delay and error of 11.3 seconds, and 71° for turning motion. Based on the recording results, a 6-minute net video was obtained with a resolution of 640x480 pixels and a framerate of 20 fps. Classification of KJA conditions reaches an accuracy level of 1 or 100% and a training loss of 0.00004. The YOLOv8 model has excellent performance in recognizing mesh objects with a very high level of accuracy. These results provide confidence that this model can be trusted in monitoring the condition of KJA nets.

To improve the performance of the YOLOv8 object detection model, several suggestions can be implemented. First, it is important to expand the training dataset by getting

more varied data. Second, it is necessary to compare the number of epochs used in model training. This is done to find the optimum point where the model achieves the best performance.

ACKNOWLEDGEMENTS

Funding for ROV development is supported by the Acoustics, Instrumentation, and Robotics (AIR) division, while field data collection activities are facilitated through the INREF WUR-IPB project.

REFERENCES

- [1] Kementerian Kelautan dan Perikanan. (2021). Statistik Kelautan dan Perikanan Indonesia Diakses pada 16 Februari 2023, dari <https://kkp.go.id/berita/25547-produksi-perikanan-budidaya-mencapai-19-8-juta-ton-kontribusi-49-02-terhadap-total-produksi-perikanan>.
- [2] Fitridge I, Dempster T, Guenther J, Nys RD. (2012). The impact and control of biofouling in marine aquaculture: a review. *Biofouling*. 28(7): 649–669.
- [3] Diarta I, Merawati L, Pramandari P. 2016. Model optimal usaha pembesaran ikan nila sistem keramba jaring apung di Danau Batur Kecamatan Kintamani Kabupaten Bangli. Prosiding Seminar Nasional Hasil Penelitian. Universitas Mahasaraswati, Bali, ID: Denpasar Press.
- [4] Biswas G, Kumar P, Mandal B, Ghoshal TK, De D, Bera A, Kailasam M. 2023. Effects of feeding frequency on growth, survival, body composition, and size variation in long whiskers catfish, *Mystus gulio* (Hamilton, 1822) fry reared in net cage system. *J Regional Studies in Marine Science*. 61.
- [5] Pongsapan DS, Rachmansyah dan Mangawe AG. 2001. Penelitian Budidaya Bandeng Intensif dalam Keramba Jaring Apung di Laut. Di dalam: Teknologi Budidaya Laut dan Pengembangan Sea Farming di Indonesia. Departemen Kelautan dan Perikanan bekerja sama dengan *Japan International Cooperation Agency*. Jakarta. Halaman 323-333.
- [6] Sunyoto P. (1994). Pembesaran Kerapu dengan Keramba Jaring Apung. Penebar Swadaya, Jakarta. 65 Halaman.
- [7] Dürr S dan Watson DI. 2010. Biofouling and antifouling in aquaculture. In: Durr S, Thomason JC, editors. *Biofouling*. West Sussex (UK): Wiley-Blackwell; p. 267–287.
- [8] Jiang B, Guo QK, Li ZC, Guo YX, Su AL, Li W, Liu C, Li AX. 2022. Biofouling of nets is a primary source of cryptocaryoniasis outbreaks in cage cultures. *J Aquaculture*. 550.
- [9] Samosir TH, Masengi KWA, Kalangi PNI, Iwata M, Mandagi IF. 2012. Aplikasi *Remotely Operating Vehicle* (ROV) dalam penelitian kelautan dan perikanan di sekitar perairan Sulawesi Utara dan Biak Papua. *Jurnal Ilmu dan Teknologi Perikanan Tangkap*. 1 (1): 22-25.
- [10] Koli MAH, Marindani ED, Hartoyo A. 2015. Rancang bangun robot bawah air mini ROV (Remotely Operated Vehicles) berbasis mikrokontroler ATMega16. *Jurnal Teknik Elektro Universitas Tanjungpura*. 1(2).
- [11] Darmawan, M. Wirman. (2009). Identifikasi Mutu Buah Mangga Arum Manis Berdasarkan Warna Menggunakan Image Processing dan JST. Yogyakarta: Jurusan Teknik Elektro Universitas Gadjah Mada.
- [12] Prabowo DP, dan Pramunendar RA. 2019. Implementasi metode CLAHE menggunakan parameter distribusi untuk meningkatkan kualitas citra objek bawah air. Prosiding SNST Fakultas Teknik. 1(1).
- [13] Ultralytics. 2023. YOLOv8 Docs. <https://docs.ultralytics.com/>.
- [14] Mahardhika AA, Saptono R, Anggrainingsih R. 2016. Sistem klasifikasi feedback pelanggan dan rekomendasi solusi atas keluhan di upt puskom uns dengan algoritma naive bayes classifier dan cosine similiarity. *J. Teknol. Inf. ITSmart*. 4(1):36.

- [15] Luquea A, Carrasco A, Martínez A, Heras. 2019. The impact of class imbalance in classification performance metrics based on the binary confusion matrix. *Pattern Recognition*. 91: 216-231. doi.org/10.1016/j.patcog.2019.02.023.
- [16] Ruuska S, Hämäläinen W, Kajava S, Mughal M, Matilainen P, Mononen J. (2018). Evaluation of the confusion matrix method in the validation of an automated system for measuring the feeding behaviour of cattle. *Behavioural Processes*. 148:56–62. doi.org/10.1016/j.beproc.2018.01.004.
- [17] Shafira T. 2018. Implementasi convolutional neural networks untuk klasifikasi citra tomat menggunakan keras [skripsi]. Universitas Islam Indonesia: Yogyakarta.
- [18] Sanila KH, Balakrishnan AA, dan Supriya MH. 2019. Underwater image enhancement using white balance, USM, and CLHE. *International Symposium on Ocean Electronics*. SYMPOL:106–116. https://doi.org/10.1109/SYMPOL48207.2019.9005301
- [19] Wai YJ, Zulkarnain, Irwan S, Chuan LK. 2018. Fixed point implementation of Tiny-Yolo-v2 using opeCL on FPGA. *International Journal of Advanced Computer Science and Applications*. 9(10):506-512.
- [20] Bai Y, Guo Y, Zhang Q, Cao B, Zhang B. (2022). Multi-network fusion algorithm with transfer learning for green cucumber segmentation and recognition under complex natural environment. *Computers and Electronics in Agriculture*. 194: 106789. doi.org/10.1016/j.compag.2022.106789.
- [21] Wu D, Lv S, Jiang M, Song H. 2020. Using channel pruning-based YOLO v4 deep learning algorithm for the real-time and accurate detection of apple flowers in natural environments. *Computers and Electronics in Agriculture*. 178: 105742. doi.org/10.1016/j.compag.2020.105742.
- [22] Xia X, Chai X, Li Z, Zhang N, Sun T. (2023). MTYOLOX: Multi-transformers-enabled YOLO for tree-level apple inflorescence detection and density mapping. *Computers and Electronics in Agriculture*. 209:107803. doi.org/10.1016/j.compag.2023.107803.
- [23] Shinde S, Kothari A, Gupta V. (2018). YOLO-based Human Action Recognition and Localization. *Procedia Computer Science*. 133: pp. 831–838.
- [24] Li Y, Huang H, Chen Q, Fan Q, Quan H. 2021. Research on a Product Quality Monitoring Method Based on Multi-Scale PP-YOLO. *IEEE Transactions on Image Processing*. 9: 80373- 80387. 10.1109/ACCESS.2021.3085338.